

TOOLS & ADVANCEMENTS IN 3D PULLEY FINITE ELEMENT ANALYSIS FOR BELT CONVEYORS

Ryan Lemmon, David Kruse

Advanced Conveyor Technologies Inc. (AC-Tek)

This paper will describe a new 3D finite element analysis tool for analysing conveyor pulleys. Previously, detailed pulley analysis could only be done using complex and expensive finite element analysis software. Even then the effort, expertise, and time required to correctly model and interpret the results for a pulley was extensive. This new tool allows manufactures and everyday conveyor designers the ability to quickly and easily verify, compare, and optimize pulley designs.

1. INTRODUCTION

Pulleys are a critical part of a conveyor system, yet they continue to fail on an unacceptable basis. Surprisingly, many of these failures happen on new installation and within the first year of operation. After reviewing some recent failures, it was found that either the pulley analyses was incorrectly preformed, or no pulley analysis had even been performed. With the advancements in computer analysis and technology, this is simply unacceptable in this day and age.

There have been many papers written on pulley analysis and different solution methodologies. These methods range from simplified closed form solutions^{1,2}, quasi finite element methods^{3,4}, 2D axis-symmetric finite element methods^{5,6,7,8}, and full 3D finite element methods⁹.

However, all of these methods require a high level of technical ability in advanced mathematics, coding, and finite element analysis. The time and effort required to set up a model or program to analyse pulleys is significant. Unfortunately, there has not been a software package specifically designed for pulley analysis that is:

1. Easy to use
2. Fast and efficient
3. Easy to understand and interpret the result
4. Allowed design optimization and comparisons
5. Has easy to understand reports for end users and clients

AC-Tek is the publisher of the Sidewinder software. Sidewinder's sole purpose is the analyses of conveyors. When a conveyor is analysed, all pulley design loads are calculated. Pulley shafts can be designed using either CEMA B105 or AS-1403 standards. These methods provide design criteria for pulley shaft stresses and deflections. For the analysis of the pulley locking device, end disk, and rim there are only very rudimentary methods available without a preforming a full finite element analysis. Worse, these methods can be very inaccurate, and their validity depends strongly on the pulley geometry and various assumptions (which may or may not be

correct). Because of this, the most reliable method for pulley analysis is the use of the finite element method.

As such, a two-dimensional axis-symmetric finite element model that accurately models the three dimensional stresses and deflections of pulleys and shafts has been developed. This model is directly incorporated into the Sidewinder software. It has been named PAX. The engineer can seamlessly model the conveyor, and pulleys, with the same software package.

This paper compares the analysis of pulleys by the following methods:

1. Full 3D finite element analysis using the ANSYS FEA software.
2. Analysis of the 3D stresses and deflections by 2D axis-symmetric elements using the ANSYS software
3. Analysis of the 3D stresses and deflections by 2D axis-symmetric elements using the Sidewinder Software (PAX)

As will be shown, all three methods give almost identical results. However, as the PAX has specifically been optimized for pulleys, it is by far the most efficient, fastest, and easiest to use. Furthermore, post processing methods to analyse specific items such as weld stresses and the bending moment across the locking device are already built in.

2. METHODOLOGY OF FULL 3D MODEL

The basic methodology to analyse a pulley with 3D elements is relatively straight forward. The following procedure is used:

- Step 1: Build the 3D geometry
- Step 2: Apply the boundary conditions
- Step 3: Apply the pulley loads
- Step 4: Solve the solution in a single step
- Step 5: Analyse the results

To build the 3D geometry there are generally two methods that can be used.

The first method is to define the 3D shape by volumes and then directly mesh these volumes to get the 3D elements. This method will usually require contact elements between each volume as the generated elements in each part may not match one another. The contact elements transfer the loads from one volume to another. For example, a pulley will typically have the following volumes:

1. Shaft
2. Locking device assembly
3. End disk
4. Rim

This method for creating a 3D model is perhaps the easiest and requires the least amount of “finite element knowledge”. Typically, a commercial package will allow the user to directly import and mesh a 3D volume. It can also automatically add the necessary contact elements.

Unfortunately, this methodology can result in large elements, or poor meshing quality. This can lead to underestimating the actual stresses at critical locations. As such this method is not recommended.

The preferred method to building a 3D model is:

- Step 1: Build the 2D geometry
- Step 2: Mesh the 2D geometry
- Step 3: Rotate the 2D geometry to make 3D elements.

By rotating the 2D elements the 3D elements will be evenly spaced in defined rotational increments (2 degrees, 5 degrees, etc).

The main advantage of this method is that the user has excellent control in defining the element size in the 2D mesh. Visualization and checking of the 2D mesh is also much easier. The only location where the mesh is not optimal is at the shaft centre. Here the brick elements must be reduced to wedges. However, at the shaft centre, the stress gradients are very low, and this is not a critical location in terms of the stress analysis. Figure 1 shows the elements of a pulley in which the 2D elements were rotated every 5 degrees.

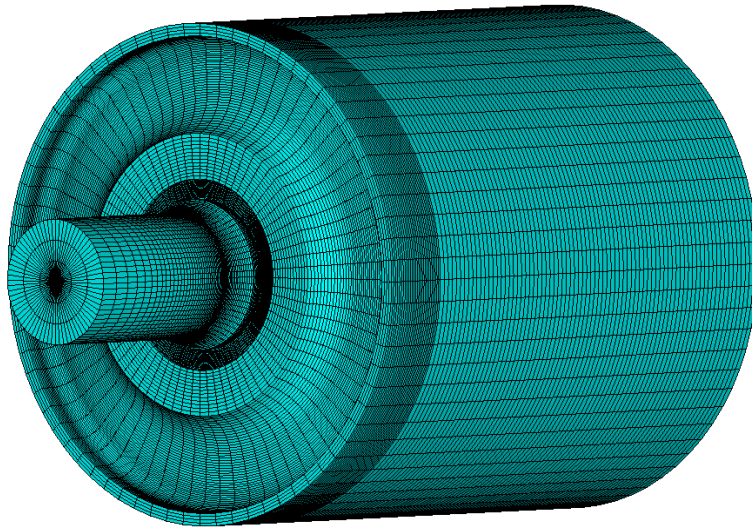

Figure 1. 3D mesh of a pulley

This paper uses the above method for the full 3D analysis.

If the pulley is symmetric around the centreline of the belt, only half of the pulley needs be analysed (as is done in Figure 1). This reduces the number of elements and nodes in half, so the run time is much faster. A symmetric boundary condition is then placed at the axial centre point. For non-driven pulleys this is always the case. It is also valid for dual drive pulleys (i.e. that have two motors that are symmetrical). However, if the pulley only has one motor, then the full pulley geometry must be analysed.

The next step in the 3D analysis is to apply the boundary conditions. Figure 2 shows a symmetric drive pulley with applied boundary conditions. The following boundary conditions and loads are applied:

1. If the pulley is symmetric, a half model is used. Symmetric pulleys include non-driven pulleys and drive pulleys that have a motor on both sides. For these pulleys, the symmetrical boundary condition of $u_z=0$ at the axial (i.e. $z=0$) location is set.
2. Apply a surface pressure at the belt to pulley contact
3. Apply a shear force at the belt to pulley contact for a driven pulley
4. Set the radial displacement to zero at the shaft centre at the bearing location
5. Apply a thermal load on the locking device to obtain the correct radial pressure at the locking device to hub interface.
6. Constrain the shaft end to prevent rotation of the pulley

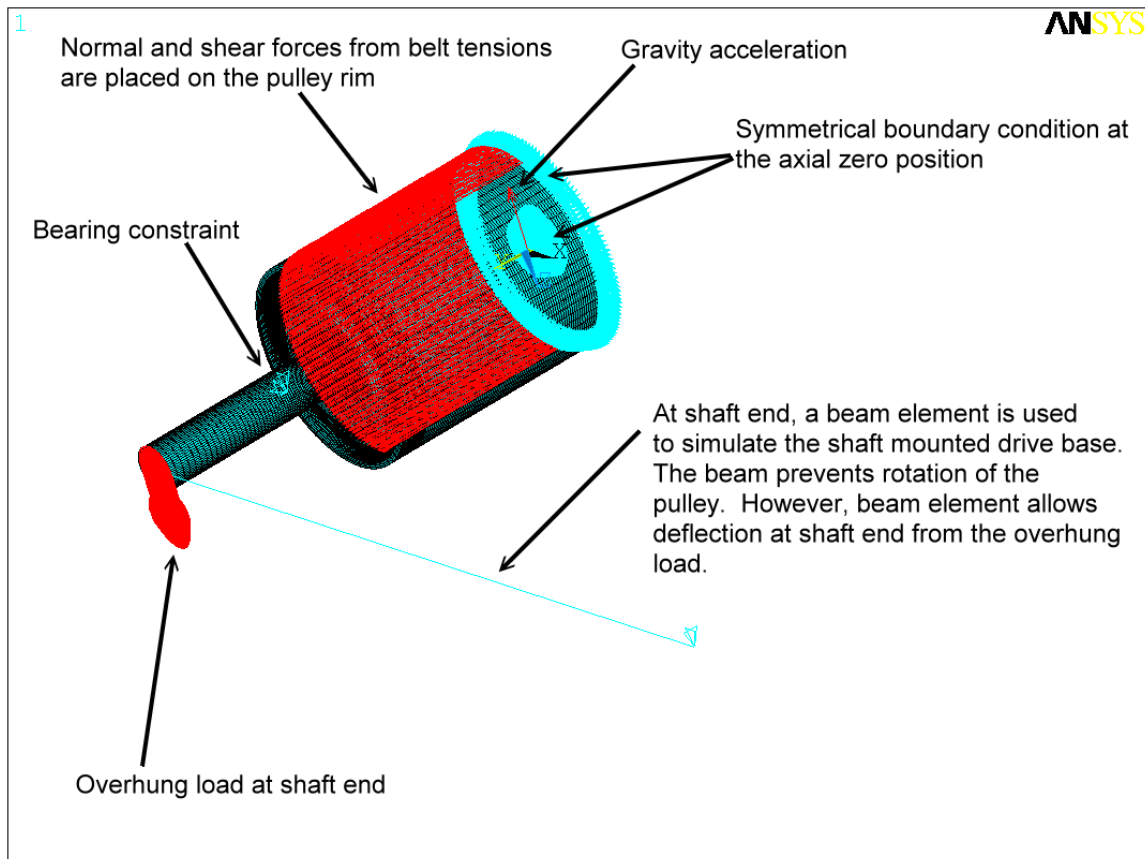

Figure 2. Boundary conditions of symmetrical drive pulley

After the boundary conditions have been applied, the model is solved. The solution only requires a single load step. After solving the results can be analysed. One of difficulties of the full 3D model is analysing the results. In a pulley analysis, the results that need to be analysed are:

1. The bending moment across the locking device.
2. The fatigue stresses including:
 - a. Alternating stress at a point. The alternating stress is:

$$\sigma_{alt} = \frac{\sigma_{max} - \sigma_{min}}{2}$$

where σ_{max} and σ_{min} are the maximum and minimum stress in 360 degrees of rotation.

- b. For calculation of the Goodman ratio, the mean stress is also required.

$$\sigma_{mean} = \frac{\sigma_{max} + \sigma_{min}}{2}$$

3. Shaft slope at the hub

To calculate the bending moment, the axial stress at each point along the length of the shaft must be numerically integrated.

$$M_x = \sum \sigma_{axial} \cdot dA \cdot r_y$$

$$M_y = \sum \sigma_{axial} \cdot dA \cdot r_x$$

dA = area of element

r_y, r_x = radius of the element on x or y axis

The bending moment on both the x and y axis is calculated. In the ANSYS software a macro can be written to do this calculation. The resultant moment is:

$$M_{Resultant} = \sqrt{M_x^2 + M_y^2}$$

Figure 3 shows the resulting bending moment (dashed line) calculation of a non-driven pulley. In this particular pulley, the theoretical bending moment at shaft centre is 37 kN-m. This assumes that the shaft takes the full bending moment (this is also the assumption in the CEMA B105 standard). However, in reality a part of the bending moment is transferred across the locking device into the end disk and rim. This is very significant and cannot be ignored. The finite element model show that the bending moment at shaft centre is only 12.5 kN-m. Therefore, the bending moment across the locking device is actually 24.5 kN-m.

Between the bearing and locking device, the theoretical and resultant moment from the finite element model should be the same.

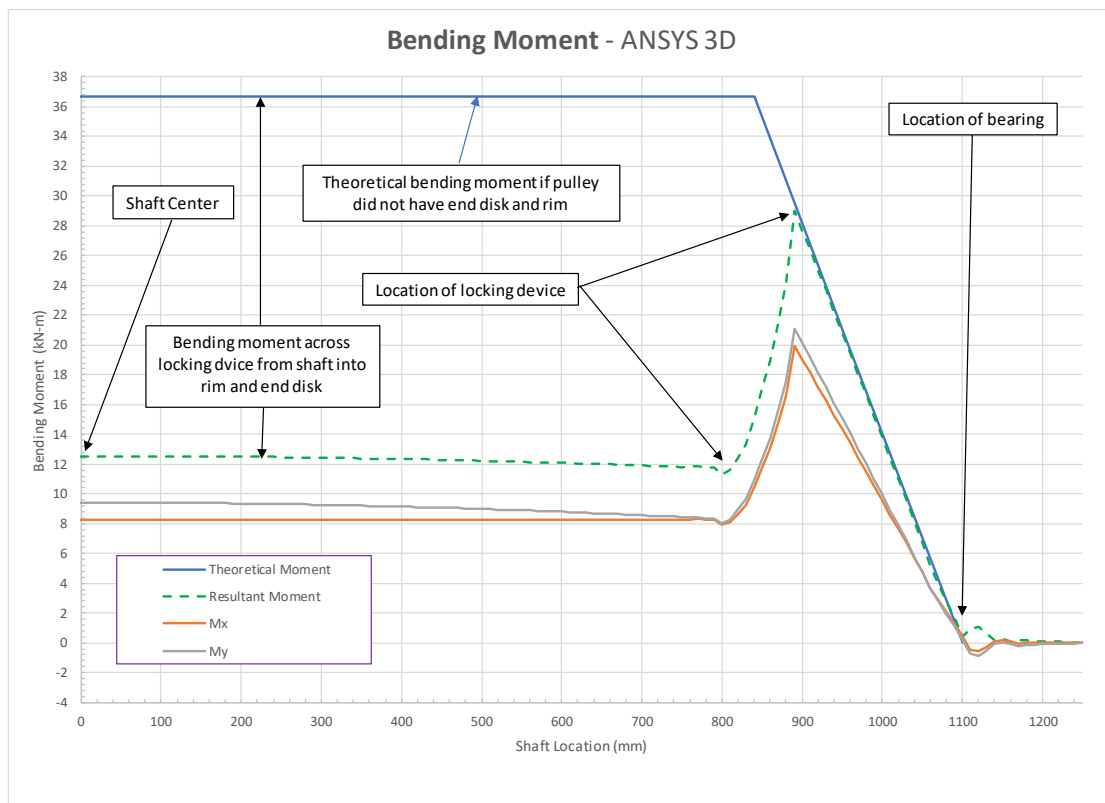

Figure 3. Bending moment calculation from finite element model

The next step in post processing is determining fatigue stresses at critical locations. One of the difficulties in the full 3D analysis is that the results can only be plotted on the full 3D geometry. However, what is really required is the fatigue stresses on a 2D cross section. From the 3D results, one must plot the stress at each cross-sectional location (i.e. axial and radial position) as a function of rotation. In the full 3D analysis there really is no easy way to do this. This will be further discussed in Section 5 “2D Axisymmetric Advantages”.

3. METHODOLOGY OF 2D AXISYMMETRIC MODEL

In this method the pulley is analysed with 2D axisymmetric elements with non-axisymmetric loading. This gives a full 3D stress and deflection analysis of the pulley using a detailed finite element mesh. The 2D axisymmetric elements (also call harmonic elements) solve the non-axisymmetric loading by defining the forces in a series of harmonic functions. Each harmonic function is defined by reducing the pressure and shear loading into a Fourier series. The 2D model is then repeatedly solved for each of the Fourier load series. Since the model is linearly elastic, the solutions from the harmonic functions may be summed together to obtain the final full 3D stress and displacements fields.

A pulley has an axisymmetric geometry in which the shaft centre is the axis of revolution. This methodology was first used in the aerospace industry in which rocket nozzles, solid-propellant grains, and spacecraft heat shields were analysed.⁵ Many researchers have used this methodology for analysing pulleys.^{6,7,8}

Several advanced commercial finite element packages have 2D axisymmetric elements in which non-axisymmetric loads can be applied. ANSYS has been used to model pulleys with 2D axisymmetric elements since the early 90's.

The basic procedure to analyse the pulley with axisymmetric elements is:

Step 1: Build 2D geometry

Step 2: Mesh 2D geometry

Step 3: Define load cases to be solved with Fourier series. In each load case, the boundary conditions and loads must be applied.

Step 4: Solve each load case

Step 5: Combine all load cases to obtain final 3D solution

Step 3 is the most complex part. The non-axisymmetric load is defined by the following equation:

$$F(\theta) = A_0 + A_1 \cdot \cos(\theta) + B_1 \cdot \sin(\theta) + A_2 \cdot \cos(2 \cdot \theta) + B_2 \cdot \sin(2 \cdot \theta) + A_3 \cdot \cos(3 \cdot \theta) + B_3 \cdot \sin(3 \cdot \theta) + \dots$$

Each of the above terms is applied in a separate load step. Each load step is then solved independently. After each load step is solved, they are summed together to obtain the final 3D solution.

In a pulley the following loads are applied:

1. Radial pressure resulting from the belt contacting the pulley
2. Shear stress at the belt contact zone on a non-driven pulley
3. Locking device load
4. Overhung loads at shaft end on a driven pulley (if present)
5. Gravity

As an example, a drive pulley with 198 degrees of wrap and an overhung load can be analysed.

For this example, it is assumed that the radial pressure applied by the belt tension is linear and proportional to belt tension around the wrap angle. The belt tension load is distributed by applying a normal pressure on the rim. This normal pressure is applied on the elements in the belt wrap contact zone. The required normal pressure is:

$$P_N = \frac{T}{b_w \cdot R}$$

At the high tension location, the pressure $P_1 = T_1 / b_w / R$. At the low tension location the pressure $P_2 = T_2 / b_w / R$.

Figure 4 shows a theoretical pressure distribution in red. The graph has been normalized such that $P_1 = 1$ and $P_2 = T_2/T_1$, where T_1 and T_2 are the high and low tension at the drive pulley. The green line is the Fourier series fit with 24 coefficients. Since each coefficient has a cosine and sine term, there are a total of 48 load cases that must be solved for the radial pressure. The Fourier series curve fit is reasonably good with the 24 coefficients.

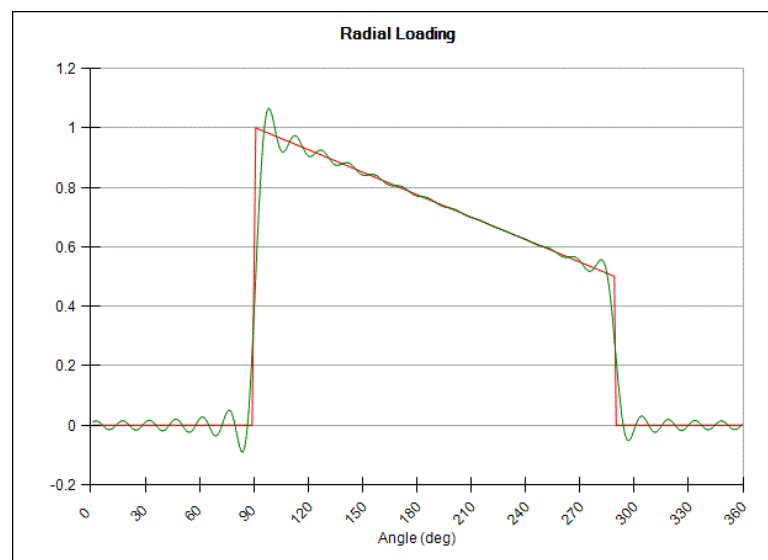

Figure 4. Fourier series fit of radial square wave with 24 coefficients

Of course, the analysis can be made faster with using fewer coefficients. Figure 5 shows the Fourier fit with 12 coefficients. The solution will run twice as fast, but the accuracy is reduced. However, even with only 12 coefficient the Fourier series fit is reasonably good. On the other hand, the analysis can be made more accurate by using more coefficients. Figure 5 also shows the curve fit with 48 coefficients. The solution will take twice as long to run. However, as the fit with 24 coefficients is reasonable, the accuracy improvement with 48 coefficients does not typically justify the extra solution time.

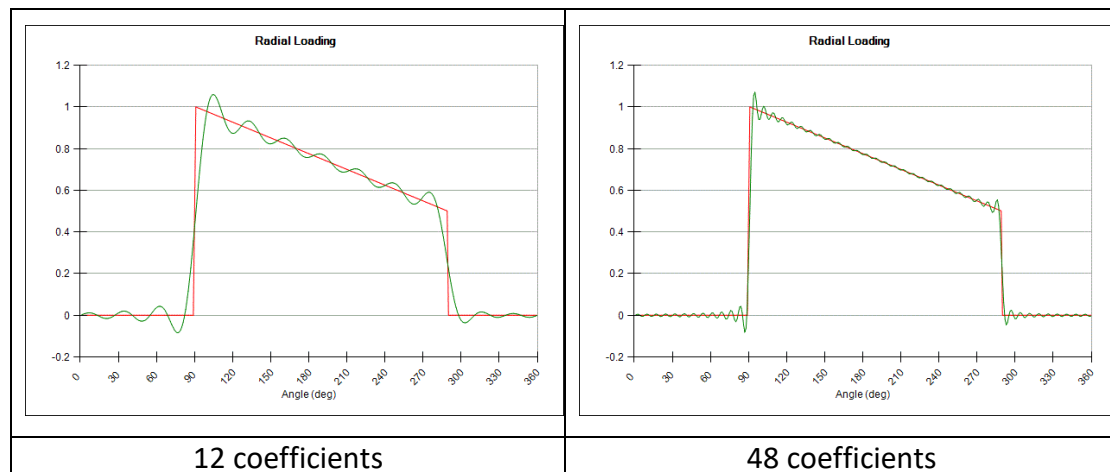

Figure 5. Fourier series fit of radial square wave with 12 and 48 coefficients

The shear stress is generally assumed to be constant in the belt contact zone. The shear stress is:

$$\tau = \frac{T_1 - T_2}{R \cdot \theta \cdot bw}$$

Where:

τ = shear pressure

bw = belt width

R = outer radius of rim

θ = wrap angle

Figure 6 shows the Fourier series curve fit assuming 24 coefficients for the applied shear stress.

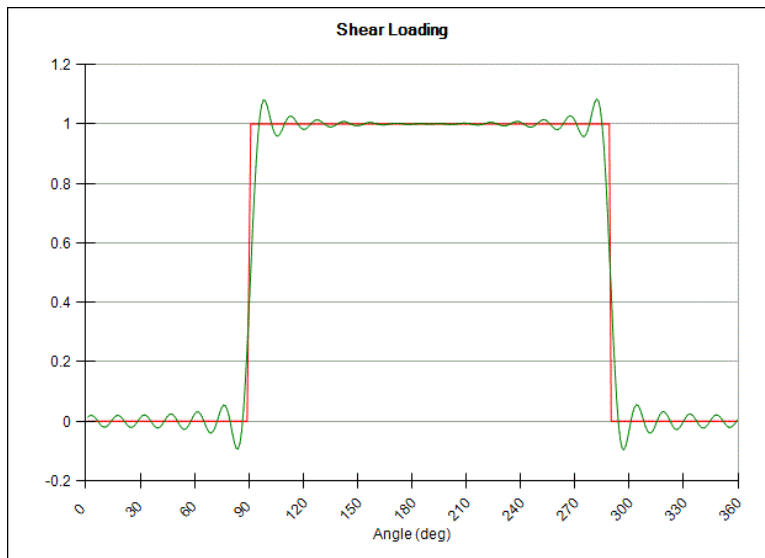

Figure 6. Shear Pressure Fourier Series (24 coefficients)

The locking device applies an axisymmetric pressure on the hub and shaft. This pressure is achieved in the finite element model by applying a thermal load in the locking device. The radial thermal expansion results in the appropriate contact pressure at the hub and shaft. Since the pressure is axisymmetric, only one load case is required for the locking device load.

The overhung load at shaft end requires two load cases. Likewise, the effect of gravity also requires two load cases.

For the example drive pulley, the total number of load cases is:

1. Radial pressure: $2 \times 24 = 48$
2. Shear stress: $2 \times 24 = 48$
3. Locking device load: 1
4. Gravity: 2
5. Overhung load: 2

A total of 101 load cases are required to solve the non-axisymmetric loading on the pulley.

In years past before workstation computer had multiple cores, the 101 solutions were solved sequentially. At that time, the main advantage of 2D axisymmetric solutions was that the memory requirements to solve one of the load cases was significantly less than that required for the full 3D solution to obtain the same degree of accuracy. This made it feasible to solve the 2D mesh with considerably smaller elements at critical stress locations. Due to memory limitations, a 3D solution was often not possible or at least not practical.

Today computers can very reasonably be purchased with 8 to 16 cpu cores and with memory capacity of 32 to 128 gigabytes. With an axisymmetric model the load cases are completely independent of one another and thus are easily hyperthreaded. For example, a computer with 8 cores can solve 8 load cases at the same time. With a typical 8 core Intel i7 processor a non-driven pulley can be solved in less than a minute. A driven pulley can be solved in only a few minutes.

Finally, after all solutions are solved the load cases are combined to obtain the final 3D solution.

4. MODEL COMPARISON

This paper will compare the results of three finite element models to analyse a pulley. These methods are:

1. Sidewinder PAX – 2D Axisymmetric model optimized for pulley analysis. The PAX model uses a 3-node triangular element (as a side note, Pax was the Roman goddess of peace. Pax is also Latin for peace. The PAX name was chosen for this software as it gives the user “peace of mind in pulley design”).
2. ANSYS 2D Axisymmetric. For the ANSYS 2D model the PLANE83 element is used. This is the “Axisymmetric-Harmonic 8-Node Structural Solid”.
3. ANSYS 3D model. For the ANSYS 3D model the SOLID186 element is used. This is the “3-D 20-Node Structural Solid”.

The ANSYS models use higher order elements in order for them to be as accurate as possible. The higher order elements have mid-side nodes that allow quadratic deformation. This is then compared to the simpler 3-node triangular element used in PAX. The 3-node triangular element was selected in PAX due to its computational efficiency and speed which allows a finer mesh to be used.

The pulley example to be analysed is a non-driven symmetrical pulley. As such a half-pulley model is used for the analysis. The basic geometry of the example pulley is:

<i>Pulley geometry and design tension</i>	
Belt width	1600 mm
Diameter	800 mm
Shaft diameter, centre	240 mm
Shaft diameter, bearing	200 mm
Bearing centre distance	2200 mm
Rim thickness	20
End Disk	Double profile
Hub centre distance	1680 mm
Locking device	Ringfeder 7015.1
Hub diameter	450 mm
Hub thickness	120 mm
Wrap Angle	88 degrees
Belt tension	194 kN

Figure 7 shows the PAX FEA elements. This model has 5768 elements and 3218 nodes. As can be seen, the elements have been refined in critical stress locations (i.e. fillet radii).

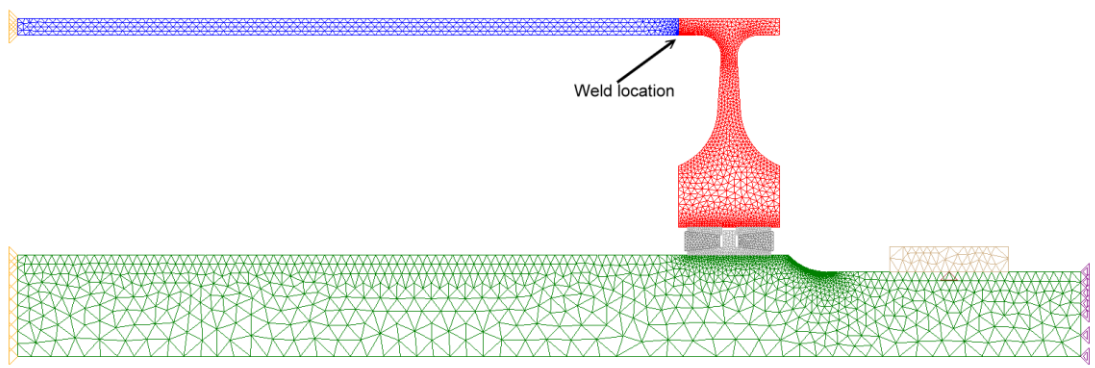

Figure 7. PAX Element Plot of Pulley

Figure 8 shows the ANSYS 2D element plot. This model has 2588 elements and 8360 nodes.

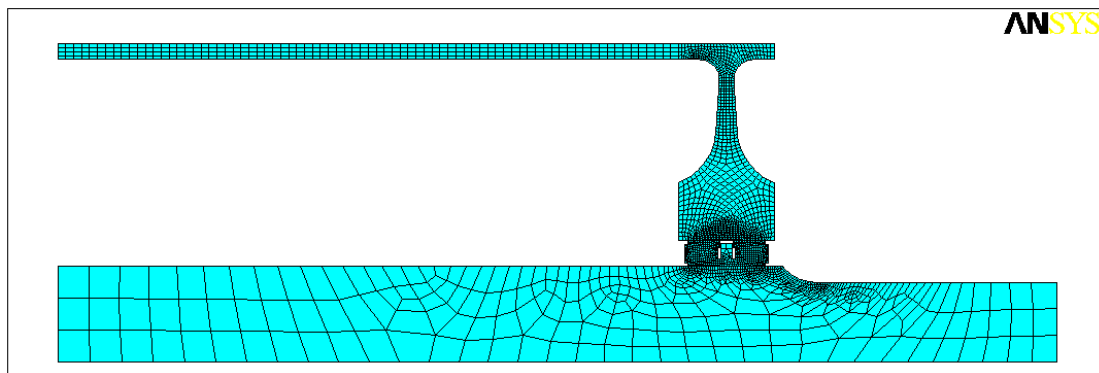

Figure 8. ANSYS 2D Element Plot of Pulley

Figure 9 shows the ANSYS 3D element plot that has been rotated at 5 degree increments.

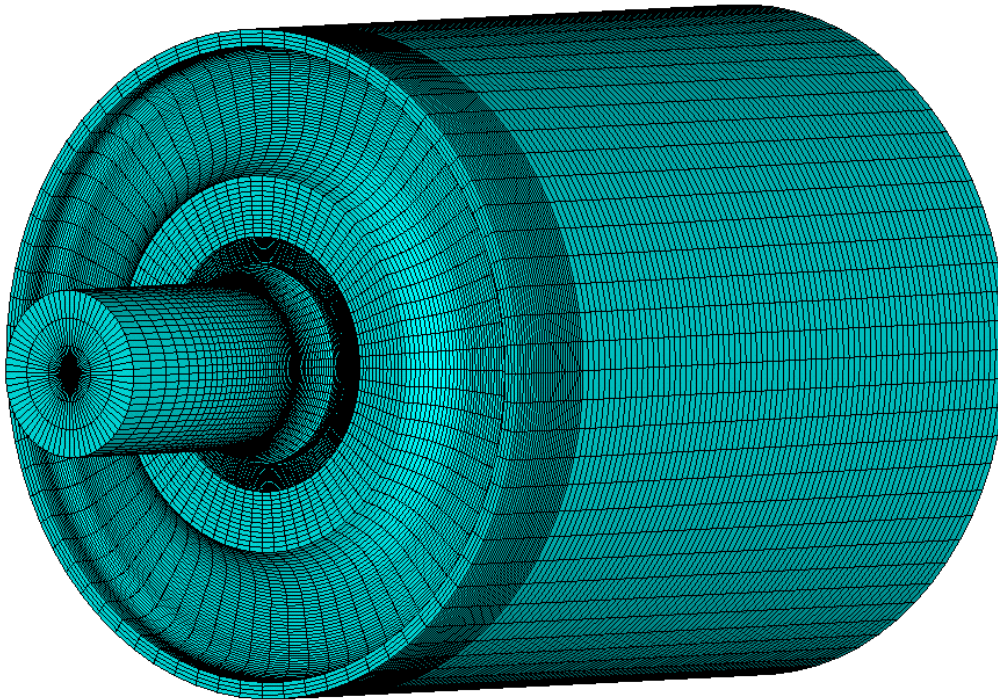

Figure 9. ANSYS 3D Element Plot of Pulley

In the 3D element model, one must decide how many angular divisions are required. This is an important question because it greatly effects the final model size and therefore memory requirements and processing time. Further if there are too many elements/nodes, a solution may not be possible depending on much memory the computer has available.

The 3D model was run at 15, 10, 5, 3, and 1 degree element angular divisions.

For the 2D models, 28 Fourier coefficients were used.

The following table shows the number of elements and nodes that are required depending on the number of angular divisions. The table also shows the solve time for each model. Typically using 5 degree angular divisions results in reasonable accuracy. However, if the wrap angle is small (i.e. < 40 degrees) then 2 or 3 degree divisions may be required.

Angular element size (degrees)	Number of elements	Number of nodes	Solve Time (seconds)
2D-PAX	6,607	3,673	43
2D-ANSYS	2,588	8,360	394
3D-ANSYS – 15 deg	62,112	277,864	667
3D-ANSYS – 10 deg	93,168	416,908	284
3D-ANSYS – 5 deg	186,336	834,040	359 (6 min)
3D-ANSYS – 3 deg	310,560	1,390,216	693 (11 min)
3D-ANSYS – 1 deg	931,680	4,171,096	4,224 (70 min)

All models were run on the same computer, which has an Intel i7-7820X CPU @ 3.6 GHz 8 core processor and 32 GB of memory. The 64-bit Windows 10 operating system allows full utilization of the memory. Both PAX and ANSYS are true 64 bit applications.

The primary result of the analysis is that PAX is substantially faster than all the ANSYS models. One reason for this is the very efficient hyper-threading implementation of the PAX solver. Additionally, the post-processing features in PAX has been thoroughly optimized specifically for pulley analysis. ANSYS, on the other hand, is multi-purpose finite element package that can be used in many different circumstances and problems. As such it has not been optimized for a specific purpose.

PAX has been designed solely for the analysis of pulleys and as such was optimized to be efficient for this one purpose.

Curiously, the 3D model that was rotated at 15 degree was much slower than the 10 degree rotation. This was due to convergence difficulties with the resulting large elements which have a significant amount of curvature. There was also a large jump in the solve time going from 3 degree rotation to 1 degree. This was a result of the much larger model and insufficient memory of the computer (memory swapping to the hard drive was required). The 5 and 3 degree rotations solved in a reasonable time frame, but still much slower (8-16 times) than the optimized PAX solution time.

The critical stress locations for this pulley are the fillet radii in the end disk and shaft. Also, of importance is the weld between the rim and end disk.

Figure 7 shows the rim weld location. The main stress components at this location are the hoop and axial (bending) stresses. Figure 10 shows the hoop, axial, and von mises stress at the weld location. This figure shows the stress from the ANSYS 3D model, ANSYS 2D model, and PAX. As can be seen, the stress levels for all three models are nearly identical. The maximum stress is 38 MPa. Figure 11 shows the von mises stress on the 3D rim geometry for both ANSYS and PAX.

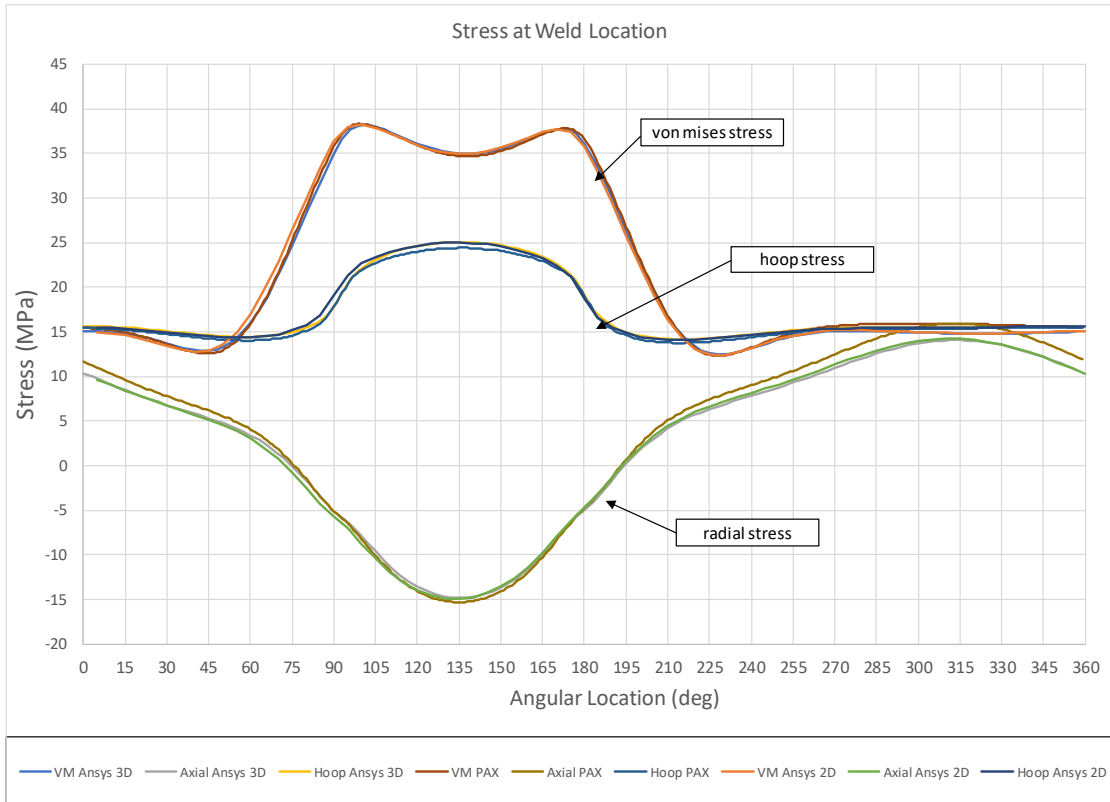

Figure 10. Stress at inside edge at the weld location between rim and end disk

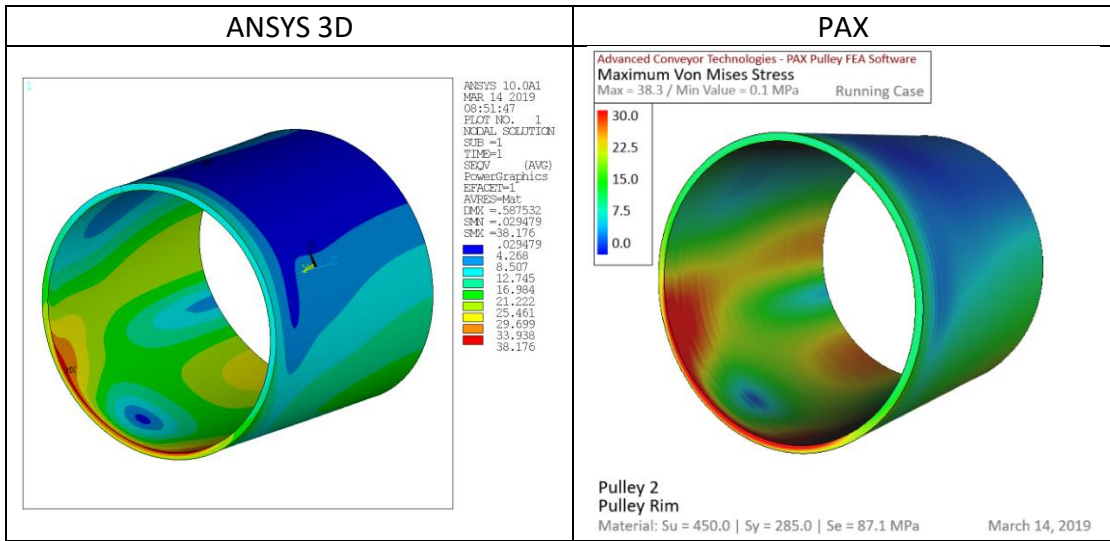

Figure 11. Stress at inside edge at the weld location between rim and end disk

One of the advantages of axisymmetric 2D element is the ability to easily plot fatigue stresses on a contour plot. Figure 12 shows the von mises alternating stress at the weld location. Welding standards list the allowable fatigue stress, which is reported as the stress range (maximum stress minus the minimum stress). However, the fatigue stresses are typically listed as the “alternating stress”. This is simply half the stress range:

$Stress\ range = maximum\ stress - minimum\ stress$

$$Alternating\ Stress = \frac{maximum\ stress - minimum\ stress}{2}$$

Again, the results show that the ANSYS 3D, ANSYS 2D and PAX results are the same. The maximum alternating von mises stress at the weld location is 33 MPa.

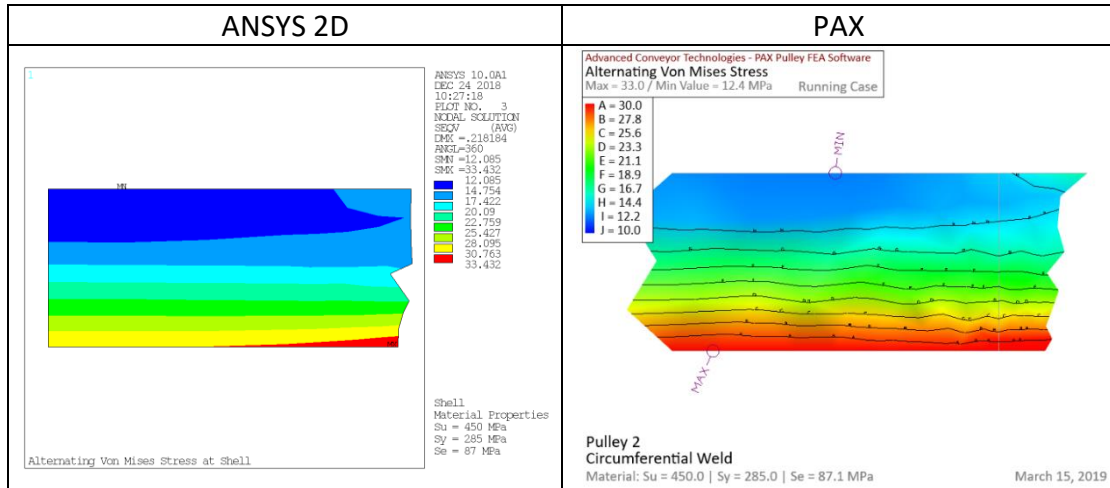

Figure 12. Alternating stress at inside edge at the weld location between rim and end disk

The maximum fatigue stress in the end disk often occurs at the top inside fillet radius. Figure 13 shows alternating stress contour plot at the top inside fillet in the end disk. The maximum alternating von mises stress is 46 MPa for ANSYS 2D and is 47 MPa for PAX. Figure 14 shows the stress on a 360 degree rotation at the location of the maximum stress in this fillet. As can be seen the stresses are nearly the same for both the full 3D model and the two 2D models.

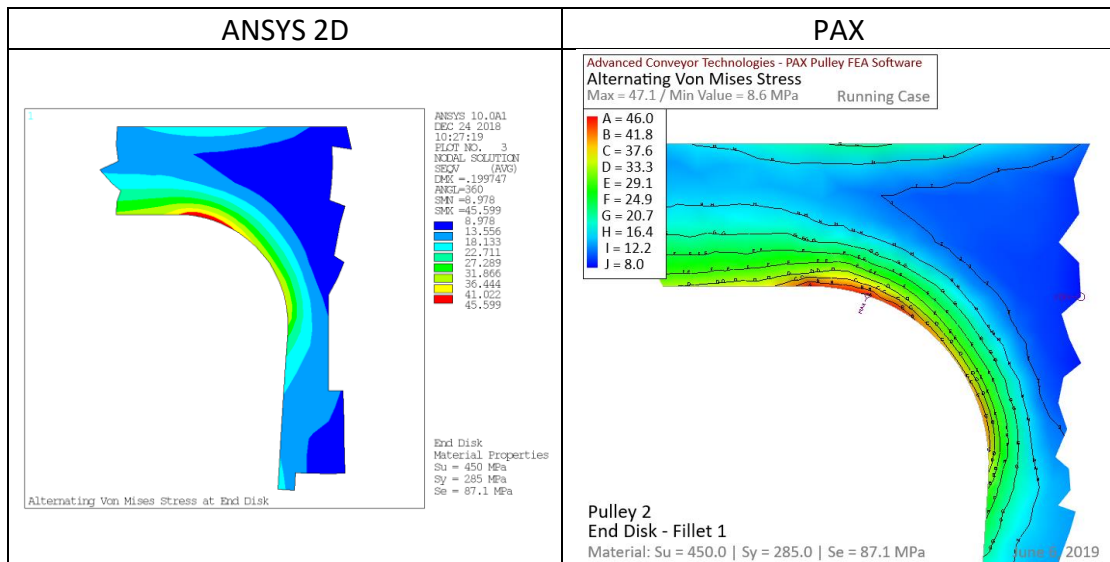

Figure 13 Alternating stress at inside edge at the weld location between rim and end disk

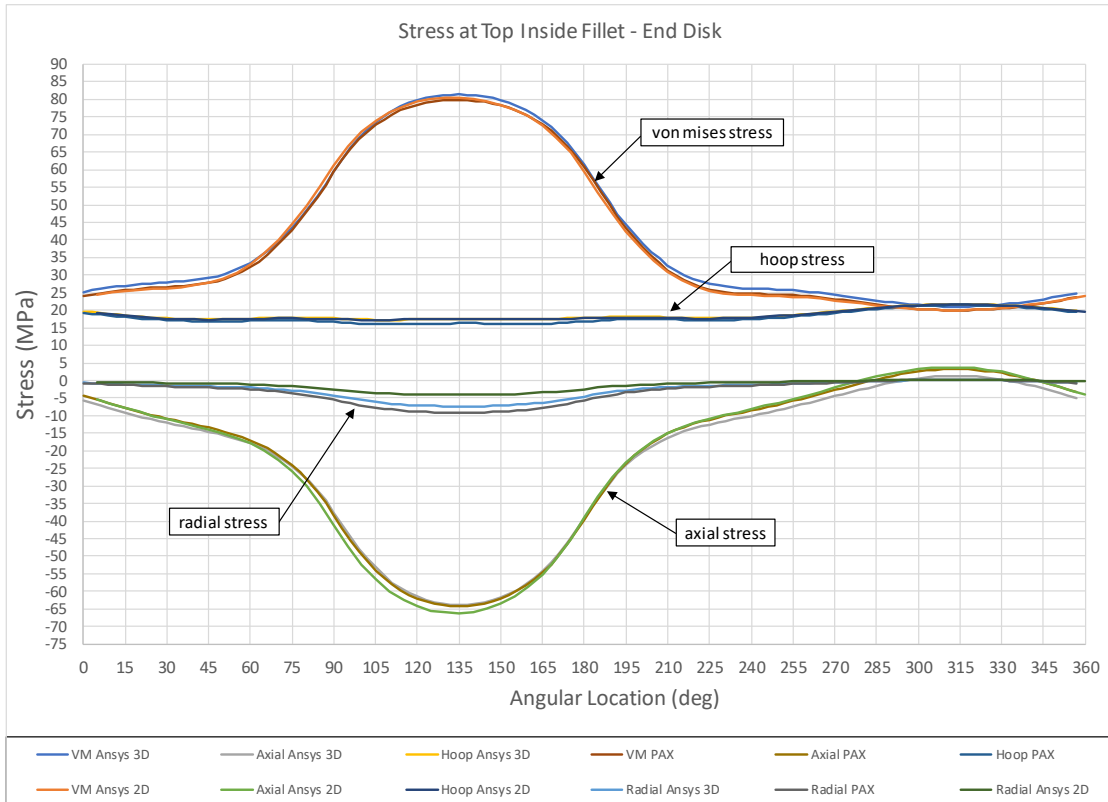

Figure 14. Stress at top inside fillet in the end disk

Figure 15 shows the von mises stress on the 3D geometry for ANSYS 3D and PAX. The contour lines have been set to 10 to 80 MPa in order to highlight the stress in the top fillet.

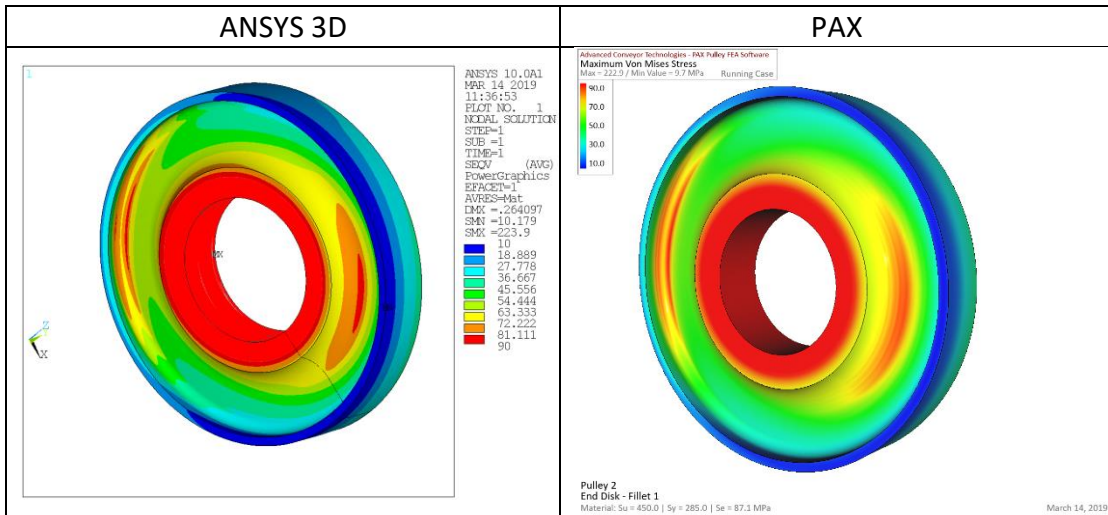

Figure 15. Von mises stress in end disk

The maximum stress in the shaft normally occur at the fillets. This pulley has one fillet between the end disk and bearing. Figure 16 shows von mises alternating stress contour plot at the shaft fillet. The maximum alternating stress is 37 MPa for ANSYS 2D and is 38 MPa for PAX. Figure 17 shows the stress on a 360 degree rotation at the location of the maximum stress in this fillet. As can be seen the stresses are nearly identical for both the full 3D model and the two 2D models.

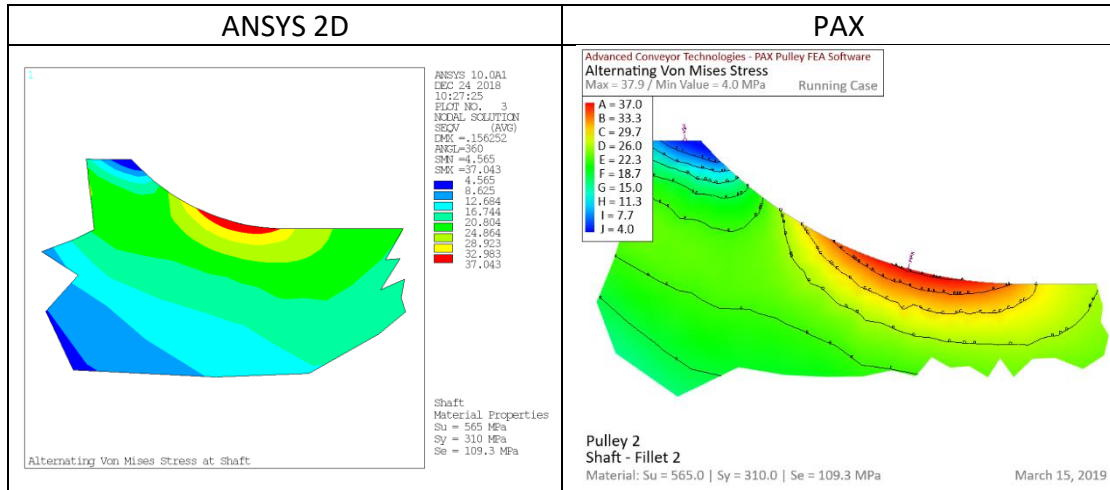

Figure 16. Alternating stress at bearing fillet in shaft

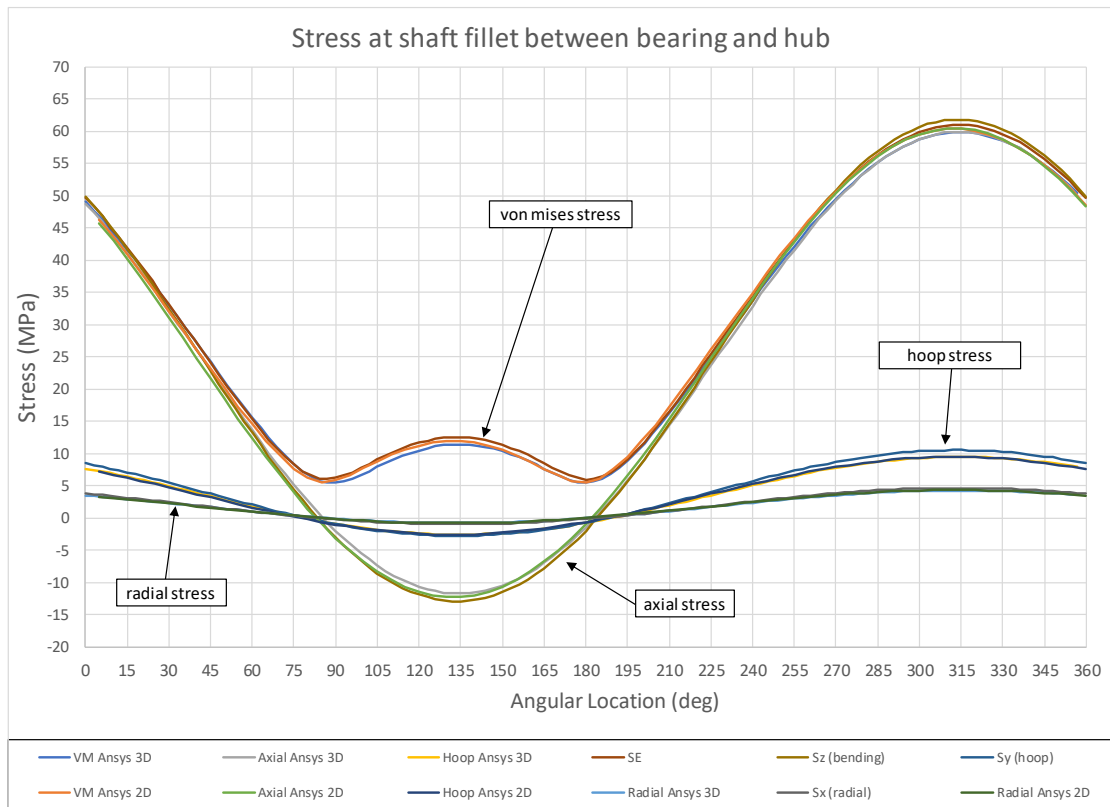

Figure 17. Stress at shaft fillet between bearing and hub

Figure 18 shows the bending stress in the shaft on the 3D geometry for ANSYS 3D and PAX. The maximum bending stress in PAX is 63 MPa and is 61 MPa in ANSYS.

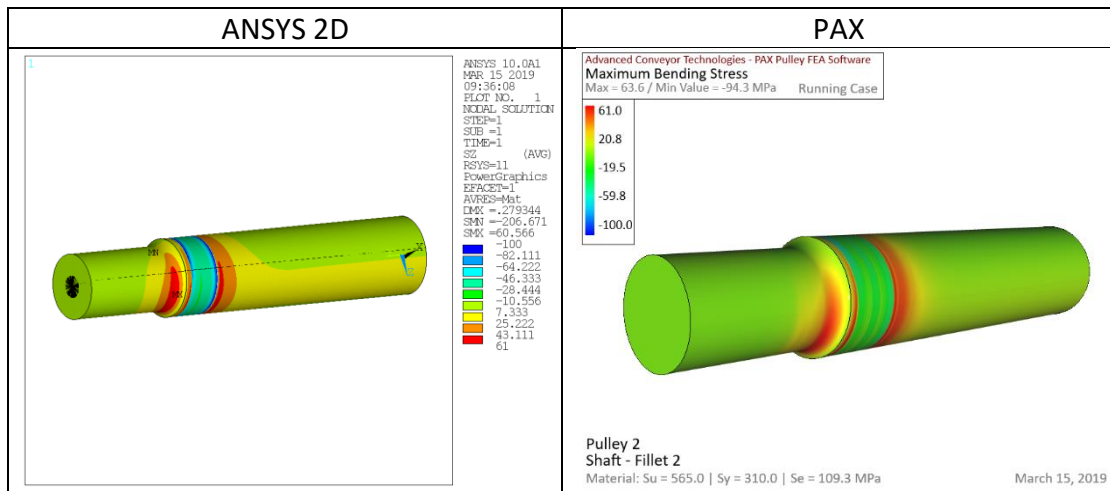

Figure 18. Axial (bending) stress in shaft

Of critical importance to pulley design is the actual bending moment transferred from the shaft to the end disk and rim through the locking device. Locking device manufacturers list the allowable bending moment in their literature. One of the most difficult calculations in pulley analysis is determining how much bending moment is transferred from the shaft to the rim through the locking device. There is simply no accurate closed form solution to calculate this value. As previously discussed, the only accurate way is to complete a finite element analysis of the pulley.

Figure 19 shows the bending moment in the shaft. The blue line is theoretical bending moment. This line assumes that the entire bending moment is in the shaft. In other words, the theoretical calculation assumes the shaft does not have an end disk or rim. In this pulley, the theoretical bending moment at shaft centre is 36.7 kN-m. The finite element model shows that the actual bending moment between the hubs is 11.7 kN-m. Therefore, the bending moment transferred by the locking device is 25 kN-m. Both the full 3D analysis and 2D axis-symmetric analysis give the same results for this bending moment.

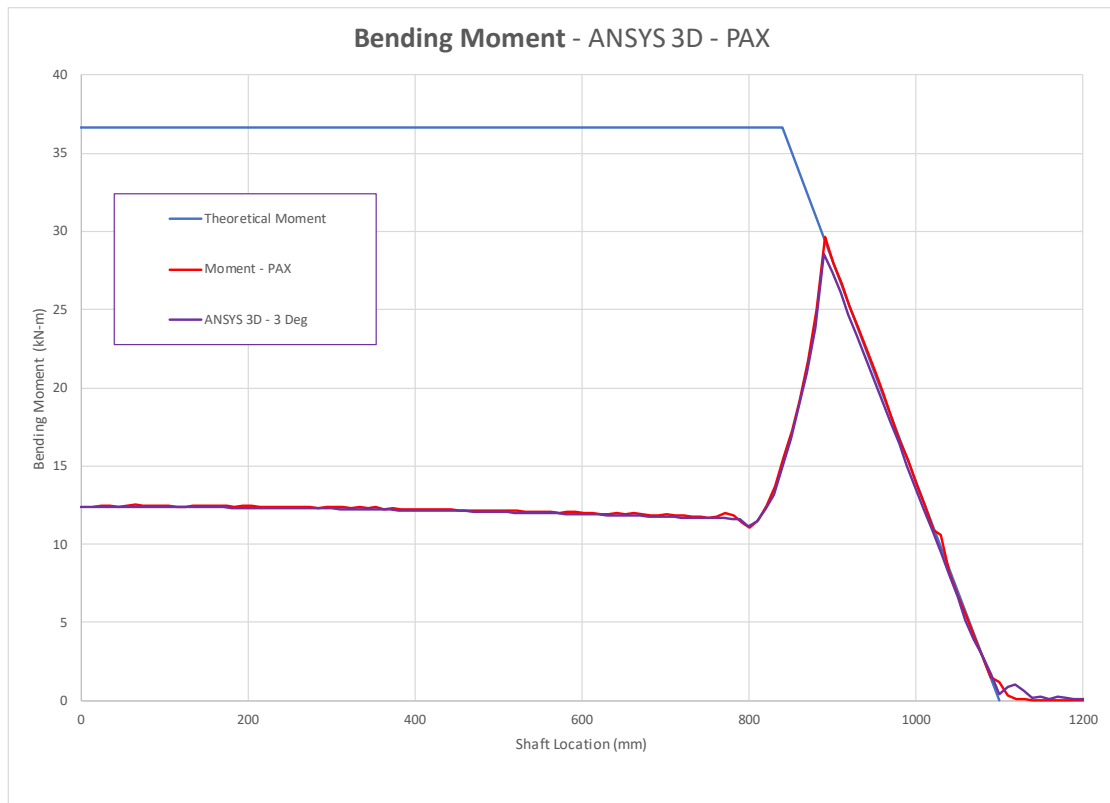

Figure 19. Bending moment in shaft

In this example, the results between ANSYS 3D, ANSYS 2D axis-symmetric, and PAX 2D axis-symmetric are nearly the same. However, due to the specific optimization and hyperthreading of the multiple load cases, PAX completes the solution significantly faster.

This comparison has been made on many pulleys with different geometries and loadings. The results have been found to be nearly the same in all cases. Figure 20 shows various pulleys that were analysed by both ANSYS and PAX.

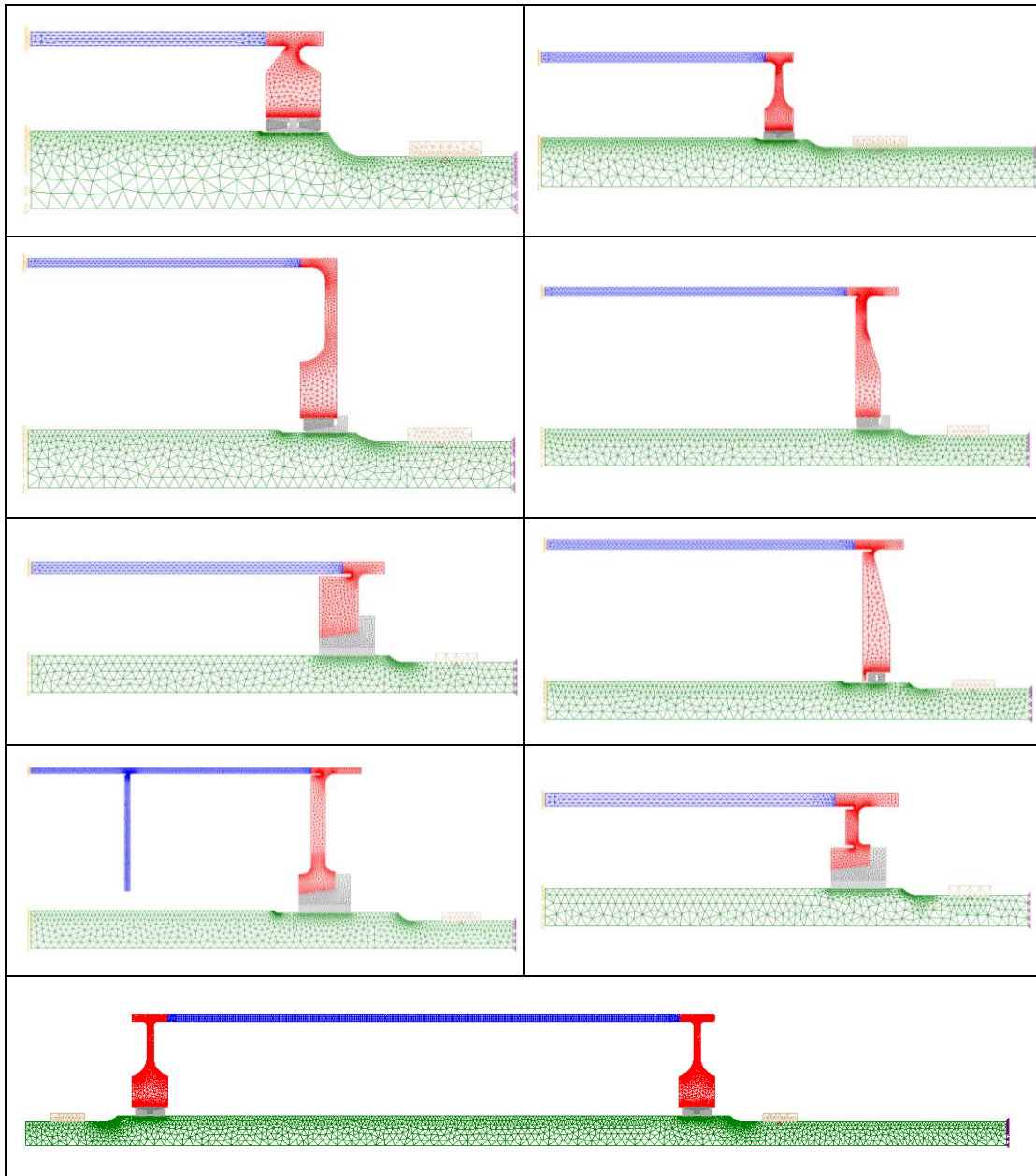

Figure 20. Various pulley geometries analysed using full 3D and 2D axis-symmetric elements

PAX is a completely parametric model that allows just about any pulley geometry to be modelled in a few minutes. This is an enormous advantage over a commercial finite element package where the geometry must be defined by defining individual key points. Lines are then defined by connecting key points. Areas are made by connecting the lines. The areas are then meshed to obtain the final geometry. This allows for any geometry to be defined. However, it is a very involved process that requires careful checking. If the geometry must be changed, then the individual key points, lines, and areas must be manually adjusted and remeshed. Also, the user must manually define the mesh size at each location.

With the fully parametric model in PAX, the geometry is easily changed by simply adjusting the input dimensions. All meshing is then automatically updated. Completing a finite element model of a pulley in PAX can be done very quickly.

Conversely, the time to complete a finite element model in a commercial program (even by a skilled users) is substantially longer. It strongly depends on the amount of pre and post processor macros, programs, and spreadsheets that the engineer has developed for the analysis processes.

Before we developed PAX, we wrote a dedicated program for the pre and post processing portion of the ANSYS modelling. Figure 21 shows the interface of this program.

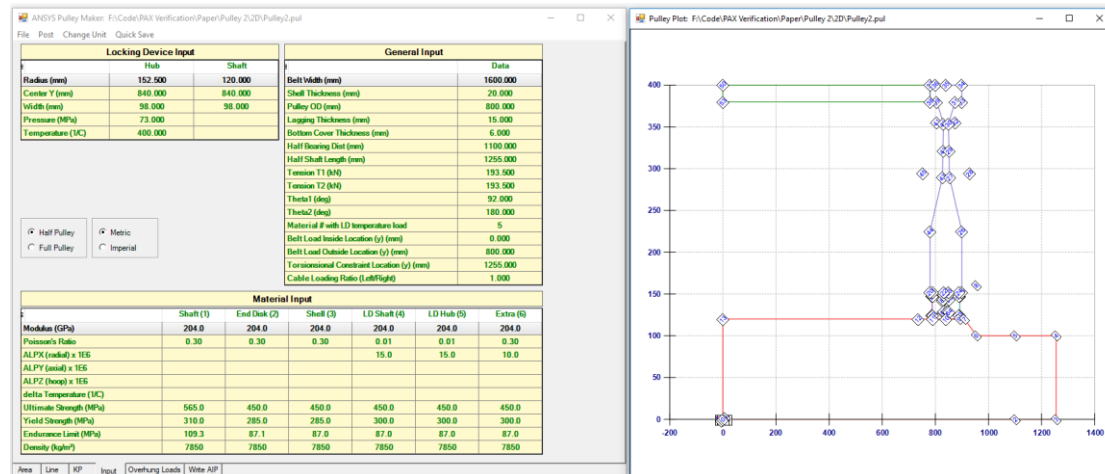

Figure 21. AC-Tek’s interface of ANSYS Pulley Maker

The basic procedure for modelling a pulley in ANSYS is:

1. Draw the pulley in AutoCAD. Each part (i.e. shaft, locking device, end disk, and rim) is drawn as polyline. The drawing is then saved as a DXF file.
2. Import the DXF file into ANSYS Pulley Maker. The program then takes the polyline and converts it into key points, lines, and areas.
3. Set mesh size at each line or key point.
4. Set material properties, loads, etc.
5. Pulley Maker then writes an ANSYS input file. This file is written in the APDL program language.
6. Open ANSYS and read in geometry so that the mesh can be verified.
7. Adjust meshing parameter to obtain desired mesh
8. Repeat steps 6/7 until satisfied with mesh
9. Pulley Maker then makes final ANSYS input file, which includes:
 - a. pre-processing input
 - b. boundary conditions
 - c. loads including definition of the Fourier series
 - d. solution steps
 - e. combining the Fourier series load cases
 - f. Post processing including plotting stresses at critical locations, bending moment and torque on shaft, loads on bending moments, shaft deflections, etc.

After the analysis was complete, the report needed to be manually written.

Even with the ANSYS Pulley Maker interface, analysing a pulley normally takes at least 3 to 4 hours. Further, development of the Pulley Maker interface took a significant amount of effort and time.

PAX however does it all; pre-processing, solution, post-processing, and report generation. Since PAX was specifically written to analyse pulleys, the end user does not need extensive finite element experience and knowledge to analyse the pulley. The user can focus on designing the pulley, rather than all the intricacies of FEA analysis. Post processing is completed internally, and the main results are summarized so they can be easily understood.

PAX also has the added advantage of automatic report writing. A professional report is automatically generated that can be sent to a client as needed.

5. 2D AXISYMMETRIC ADVANTAGES

The conclusion of the finite element modelling of a pulley with a full 3D element model versus a 2D axisymmetric model with non-axisymmetric loading is that both models give the same results. However, the 2D axisymmetric model has the following advantages:

Advantage #1: The run time of the 2D model is much faster due to the ability to hyper-thread the individual load cases. It was found that a 2D axisymmetric model that has been hyperthreaded and optimized runs 15 to 30 times faster than a full 3D model. The PAX model also runs much faster than ANSYS 2D axis-symmetric model due to the hyperthreading of the solutions.

Advantage #2: The 2D model can be run on computer with less memory. In fact, if one's computer is somewhat limited in memory (i.e. less than 8 GB) a 3D model typically won't converge due to lack of memory, or the run time may be excessively long. Even if the computer has enough memory, the 2D model will be much faster due to the ability to have additional threads solving at the same time.

Advantage #3: The 2D model has better visualization of the fatigue stresses. In the 3D model, the results show the stress at all locations. However, in a pulley analysis, what is required are the stresses on the 360 degree rotation which has been reduced to alternating stress and mean stress. From the alternating and mean stress, the Goodman ratio (fatigue stress) and Yield ratio (maximum stress / Yield Strength) can be calculated and plotted for easy visualization. For example, Figure 15 shows the stress in end disk of the 3D model. If only the 3D stresses are available then the fatigue stress at a specific location must be manually calculated (or calculated using a macro). In figure 15 the maximum stress in the fillet is approximately 90 MPa and the minimum stress is approximately 35 MPa. Note that the contours have been set to a maximum of 90 MPa so that maximum stress in the fillet can be seen. The maximum stress (which is 220 MPa) occurs in the hub, and is due to the locking device pressure.

A further complication of calculating the fatigue von mises stress is that von mises fatigue stress must be calculated from the individual component stresses. In other words, one cannot simply plot the von mises stress in 3D and then take the minimum

and maximum stress to obtain the alternating stress. The correct fatigue stress formula is:

$$\sigma_{VM-Alt} = \sqrt{\frac{1}{2} \left[(\sigma_{xa} - \sigma_{ya})^2 + (\sigma_{ya} - \sigma_{za})^2 + (\sigma_{za} - \sigma_{xa})^2 + 3(\tau_{xya}^2 + \tau_{yza}^2 + \tau_{zxa}^2) \right]}$$

Where, for example, σ_{xa} is the alternating stress of the x (or radial) stress in the 360 degree rotation. If the von mises stress is calculated at each location and then one assumes that the alternating stress is the maximum minus the minimum von mises stress, then the result will be incorrect. Figure 22 shows the component and von mises stress at the maximum stress location in the inside fillet radius. The plot shows that the maximum and minimum von mises stresses are 84 MPa and 20 MPa. If the alternating stress is calculated from these two values, the alternating stress would be 32 MPa. However, this is incorrect. The alternating stress must be calculated from the above formula, which shows that the alternating stress is 47.1 MPa ($\sigma_{xa}=6.1$, $\sigma_{ya}=4.1$, $\sigma_{za}=36.9$, $\tau_{xya}=5.2$, $\tau_{xza}=11.4$, $\tau_{yza}=15.6$). In summary a 3D plot of von mises stress is insufficient to calculate the fatigue stress. The alternating component stresses must be calculated and then the von mises alternating stress can be found. This is an easy calculation in a 2D axisymmetric analysis. However, commercial 3D finite element packages do not typically have an easy way to do this. As such this calculation will likely have to be externally determined from the finite element package which is both time consuming and quite tedious.

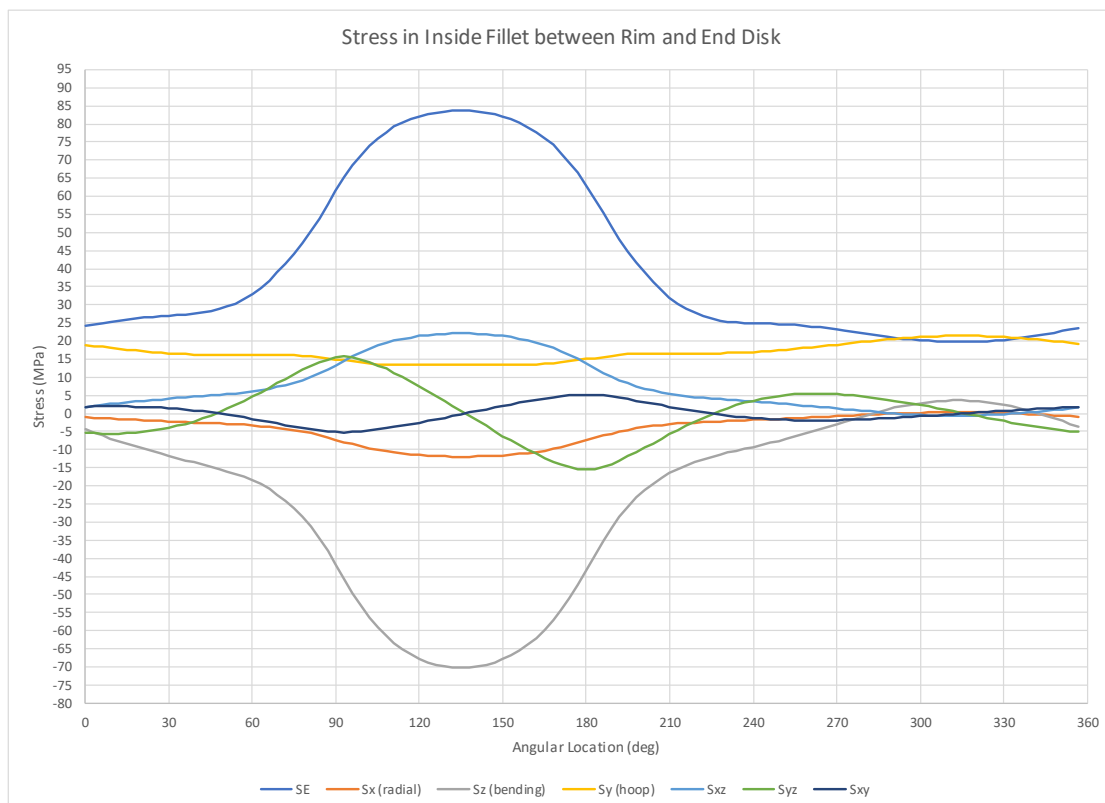

Figure 22. Contour plots of fatigue stresses and failure ratios based on full 360° rotation

With the 2D model, the fatigue stresses are easily computed and then plotted on the 2D geometry. Typical plots are: the maximum von mises stress, the alternating von

mises stress, the Goodman ratio, and the yield ratio at all critical locations. Component stresses (i.e. radial, hoop, and axial) can also be plotted as needed. Figure 23 shows these plots at the top inside fillet in the end disk. From these plots, it is immediately known the fatigue stress levels. Further, the maximum stress location is easily seen. If the stresses are too high, then a geometry change can be made to reduce them to acceptable levels.

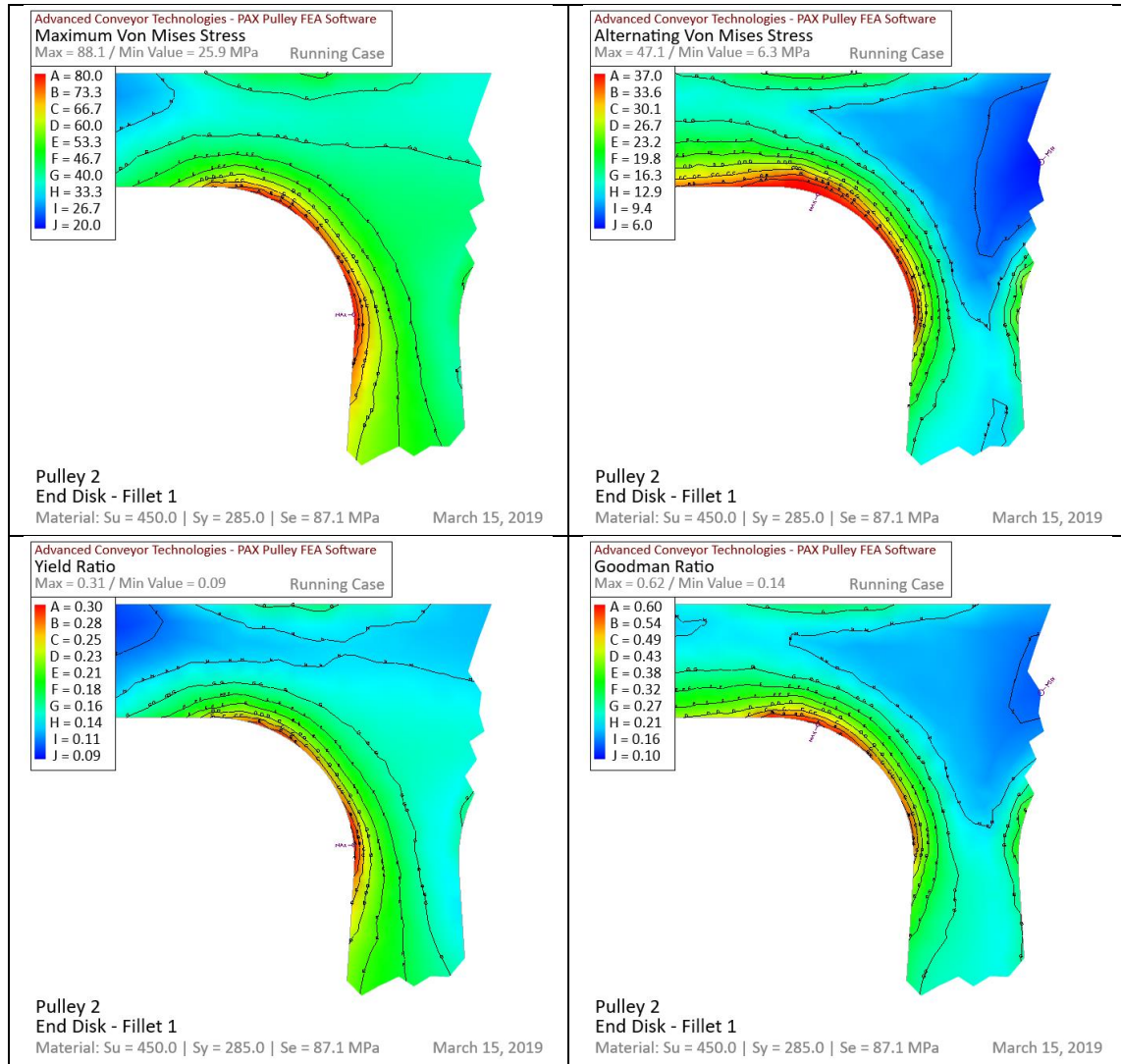

Figure 23. Contour plots of fatigue stresses and failure ratios based on full 360° rotation (PAX)

Advantage #4: The pulley that was used in this paper had a relatively simple geometry and therefore a full 3D model was possible. However, there are many pulley geometries that have much more complex geometries. Take for example a pulley that has a partial penetration weld between the end disk and rim. This is a very common pulley type, especially for low tension – fabric belt pulleys. If a designer wants to analyse this geometry, a full 3D pulley analysis will be difficult due to the small element size needed at the inside weld fillet. The gap distance between the rim and end disk is typically 1 mm to 3 mm. This requires an element size of 0.25 mm to 0.5 mm (or smaller) at the inside fillet radius.

Figure 24 shows the geometry and element plot of such a pulley. This pulley has a 500 mm diameter. The rim thickness is 22 mm. The gap between the rim and end disk is 3

mm. A partial penetration weld is completed between the end disk and rim. The weld outside fillet is 10 mm. The geometry assumes the gap length (inside edge of end disk to inside will radius) is 12 mm.

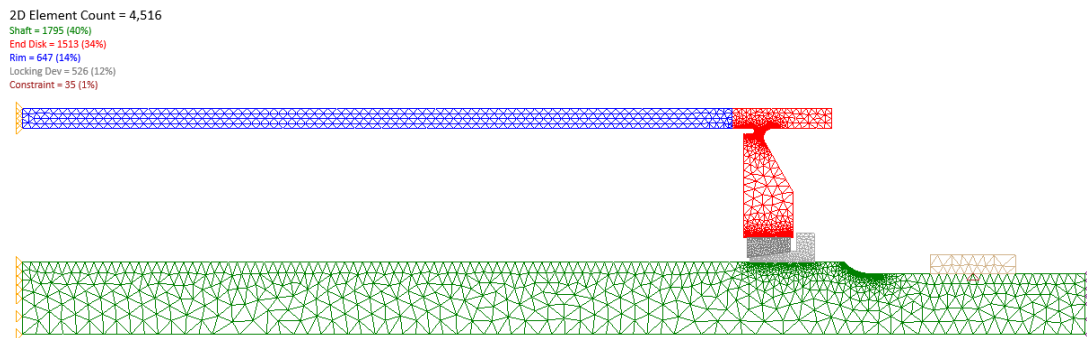

Figure 24. Low tension pulley with partial penetration weld between rim and end disk

Figure 25 zooms into the weld geometry. With the 2D axisymmetric model, it is easy to refine the elements. The element length in the 3 mm inside radius is set at 0.25 mm so that there are 38 elements in the 3 mm radius.

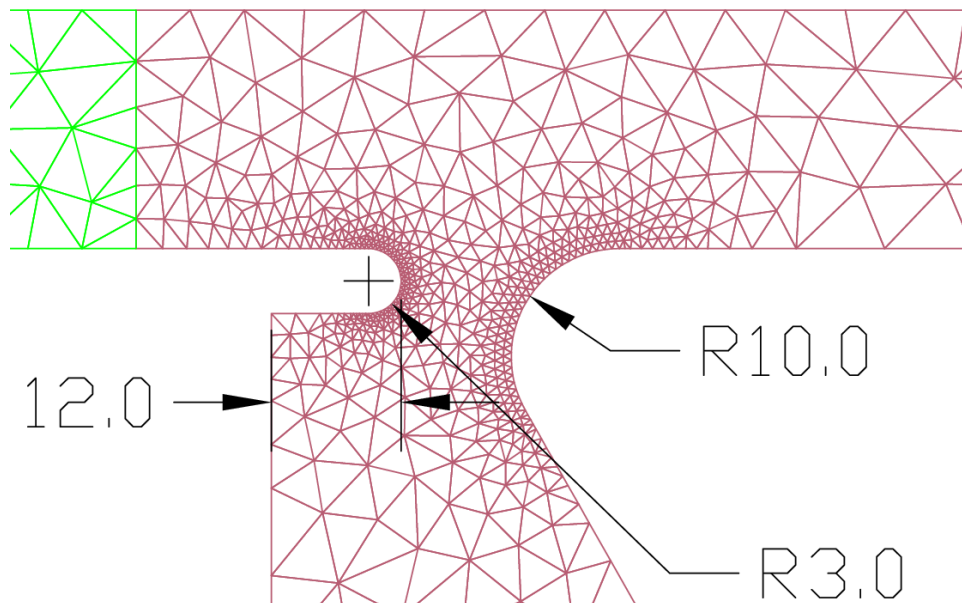

Figure 25. Zoom into weld geometry

The PAX model for this geometry solved in 22 seconds! Figure 26 shows the resulting maximum and alternating von mises stress in the weld.

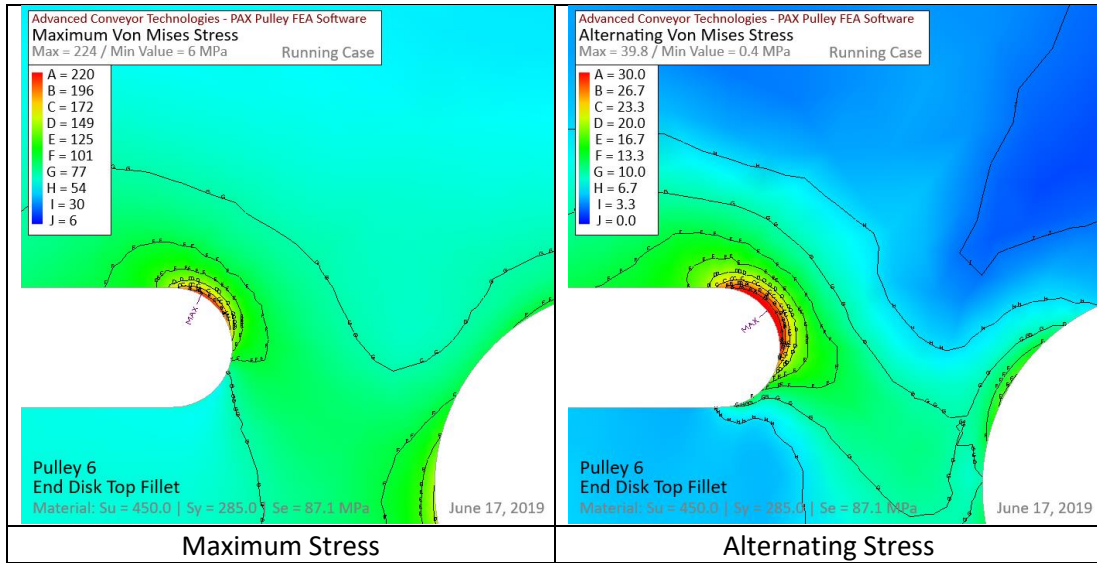

Figure 26. Alternating von mises stress in the weld (PAX)

A 3D model was built in ANSYS. The 3D model uses the 20-node element. Note that the higher order 3D element (i.e. brick element with 20 nodes) is necessary due to elements that have extreme geometric aspect ratio. Figure 27 shows 3D elements at the weld fillet. ANSYS warns that 7% of the elements in the model have aspect ratios that are beyond recommended limits. When a 3D model is used in such geometries, it will be important to check the results. However, in a 2D axis-symmetric solution, this is not an issue.

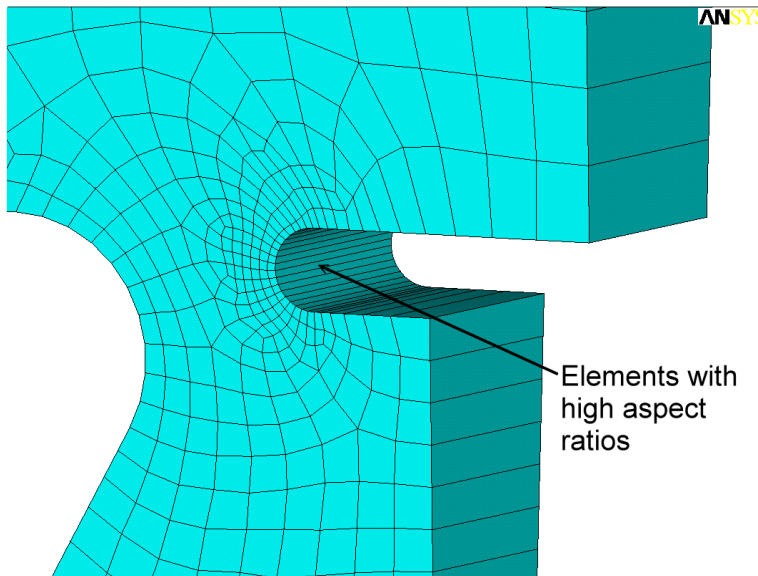

Figure 27. 3D elements at weld fillet (5 degree element rotation angle)

Figure 28 shows both the PAX results and ANSYS 3D results. The figure shows the maximum stress in the weld fillet between the end disk and rim. The ANSYS 3D model was run with angular element divisions of 10 degrees, 3 degrees, and 1 degrees.

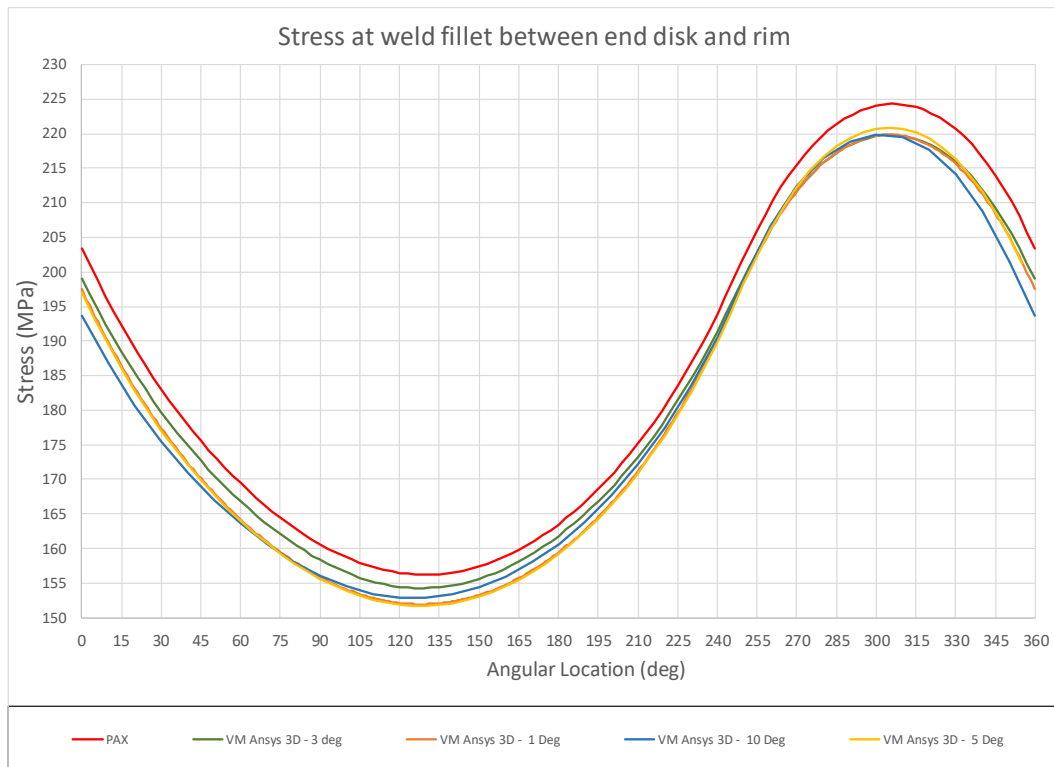

Figure 28. Von Mises stress at fillet weld between end disk and rim

The results between the 2D axis-symmetric and 3D model are similar but not the same. Even among the different 3D models there is some differences. The difference was enough that a second 3D model was made with smaller elements to obtain higher accuracy. Figure 29 shows the refined 3D model with angular element divisions of 5 degrees.

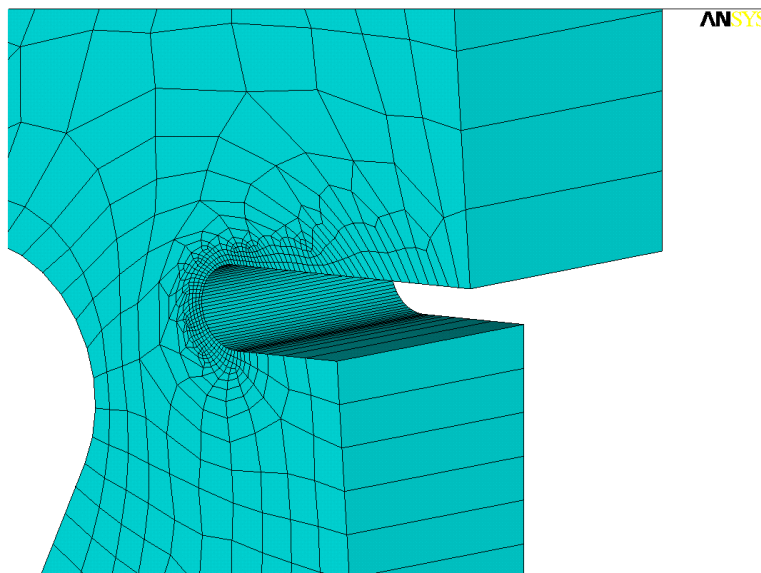

Figure 29. Refined 3D elements at weld fillet (5 degree element rotation angle)

Figure 30 shows the results of the refined meshed at the fillet weld. Even though the aspect ratios of the 3D brick elements are even more extreme, the results have converged with the refined mesh. For this model, the PAX solution again completed in

22 seconds. The refined 3D model with angular element divisions of 5 degrees ran in 845 seconds and the 3 degree model ran in 917 seconds (+15 minutes which is over 40 times longer).

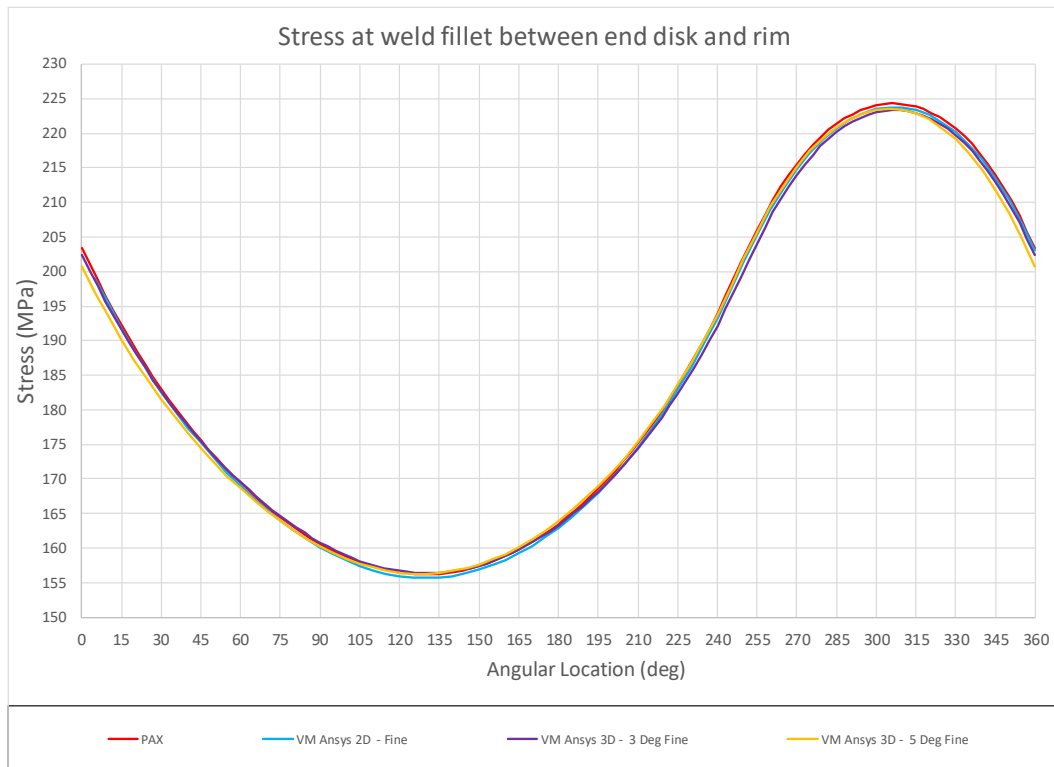

Figure 30. Von Mises stress at fillet weld between end disk and rim with refined 3D model

6. CONCLUSIONS

This paper has described a new 3D finite element analysis tool (PAX) for analysing conveyor pulleys. This method has been built into the Sidewinder conveyor design software. PAX uses 2D axis-symmetric elements to accurately and efficiently model pulleys. The 2D axis-symmetric analysis has been compared to full 3D finite element models. The results are almost identical, however, the PAX software is much easier to use, substantially faster, and the results are specifically tailored for pulley analyse.

REFERENCES

- 1 Lange, H. (1963). "Investigations on stress in belt conveyor pulleys." Ph.D. thesis, Technical Univ. Hannover, Hannover, Germany.
- 2 Jones, D. (1995) "Fatigue Failures of Welded Conveyor Drums" Engineering Failure Analysis, Vol 12 No 1
- 3 Qiu, X., and Sethi, V. (1993). "A new pulley stress analysis method based on modified transfer matrix method." J. Bulk Solids Handling, 13(4), 713–724.
- 4 Qui X., Chai C., Lemmon R. (2014) Precise Finite-Element Model for Pulleys Based on the Hamiltonian Form of Elasticity. J. Eng. Mech.
- 5 Wilson, Edward, (Dec 1965) "Structural Analysis of Axisymmetric Solids", AIAA Journal, Vol 3. No. 12
- 6 Sethi, V., Nordell L. (1993), Modern Pulley Design Techniques and Failure Analysis Methods, SME
- 7 Sethi, V., 3-D Post-Processing of Axisymmetric Analysis Data as Applied to the Stress Analysis of Conveyor Belt Pulleys,
- 8 Ravikumar M, Chattopadhyay A. (1999) Integral analysis of conveyor pulley using finite element method. Comput Struct
- 9 Affolter C, Piskoty G, Koller R, Zragger M, Rütli T (2007), Fatigue in the shell of a conveyor drum, Engineering Failure Analysis

ABOUT THE AUTHORS



RYAN LEMMON

Ryan Lemmon received both his Bachelor and Master of Science Mechanical Engineering from the University of Idaho. He is co-owner of Advanced Conveyor Technologies, Inc. His talents include design and analysis of complex conveyor, numerical analysis methods including discrete element method (DEM) and finite element analysis (FEA), data acquisition and field measurements, research and development, and programming.

Ryan Lemmon

Advanced Conveyor Technologies, Inc. (AC-Tek)
3911 East 132 North
Rigby, ID 83442 U.S.A.
(208) 745-6914
www.actek.com



DAVID KRUSE

David Kruse received his B.S. in Engineering Mechanics and Astronautics from the University of Wisconsin, Madison and his Master of Science in Aeronautics and Astronautics from the University of Washington. He is co-owner of Advanced Conveyor Technologies, Inc. His specific interests are in the areas of belt dynamics, data acquisition and field measurements, rubber rheology, and transfer chute design using the discrete element method (DEM). He has developed a wide variety of mining engineering software that is currently in use today.

David Kruse

Advanced Conveyor Technologies, Inc. (AC-Tek)
19415 594th Avenue
Mankato, Minnesota 56001, U.S.A
(507) 345-5748
www.actek.com